

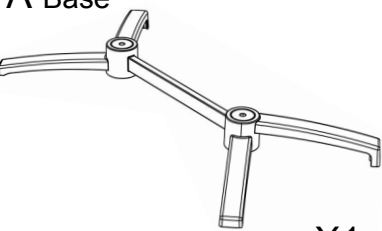





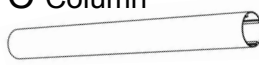

Please assemble on a clean and flat surface, such as carpet or cardboard to prevent scratches (do not assemble on your floor). PLEASE NOTE: We've tried to make this table as easy to assemble as possible. In the unlikely event you have problems putting it together or missing pieces, please contact us. Details below.

A Base  X1	B Table Top Bracket  X2	C Column  X2	D Central Bar  X2
E Nut  X2	F Washer  X2	G Spring Washer  X2	H Folding Handle Bracket  X2
			I Folding Handle Bar  X1

STEP 1

Screw the Central Bar into the Table Top Bracket B. Stop when it reaches the nut.

X 2

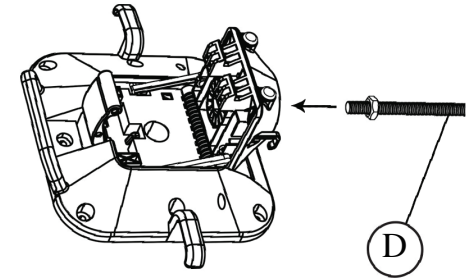

STEP 2 Slide the columns into each table top bracket. Each column fits into 3 notches in the table top bracket (and the table base – step 3). If fitted correctly the column will not turn.

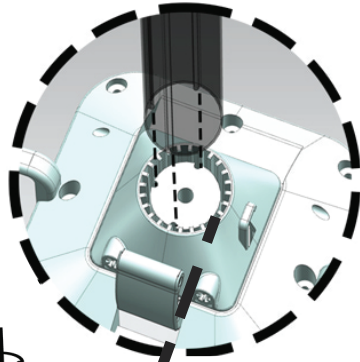

STEP 3

- Position the 2 Table Top Brackets (B) on your table top (final position can be adjusted at step 5).
- Now put one Folding Handle Bracket (H) on one side (Slide part H into the hole in the table top bracket - shown below),
- Slide the Folding Handle Bar (I) into this Table Top Bracket, then add the other Folding Handle Bracket (H). Leave enough space to allow the handle bar to turn.

Note: these parts will not be attached to the table top brackets.

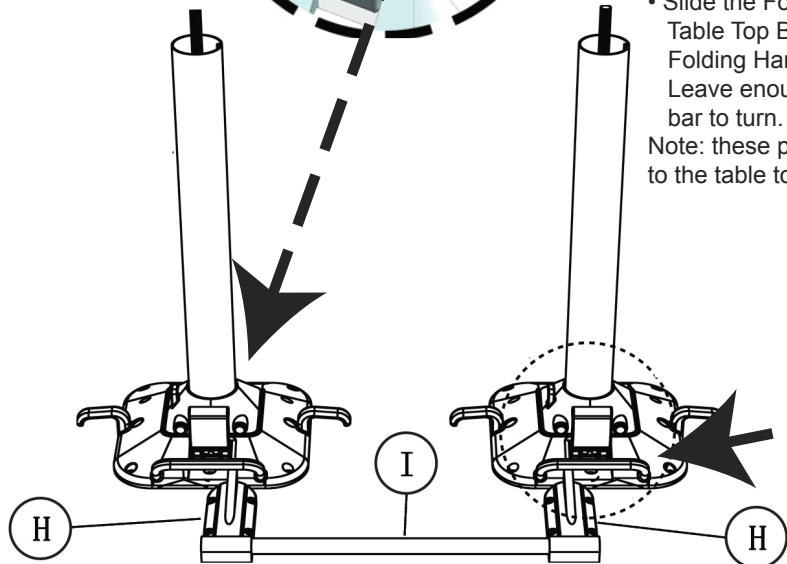

STEP 4 Locate the table base into the 2 columns. Align the 3 notches to secure. Then use parts E, F, G to secure into the Central Bar

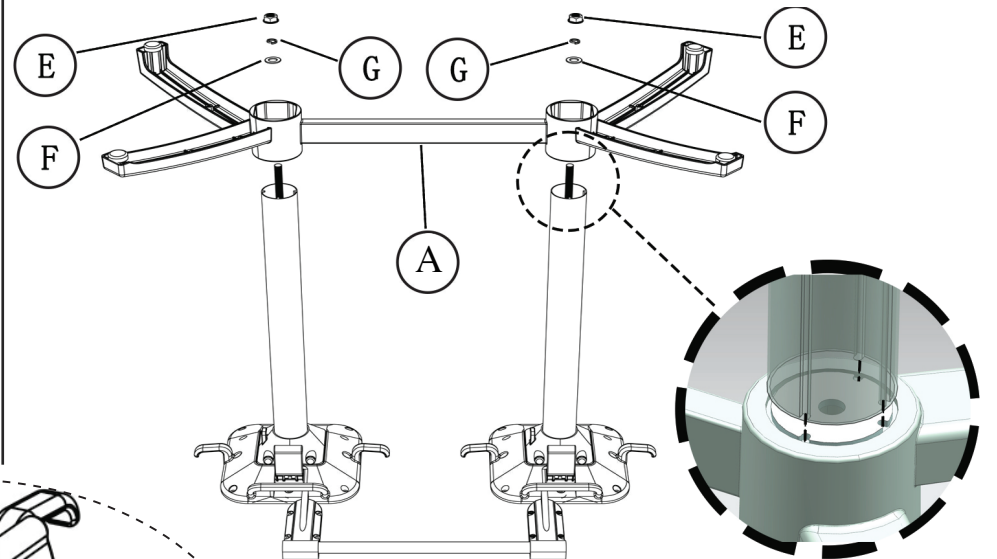

STEP 5

Now fix the Table Top Brackets and Folding Handle Brackets to your table top. (screws not supplied) Check your folding mechanism is working, and enjoy your table!

STEP 3