

CORSBEN150x35
 CORSBEN185x35
 CORSBEN230x35

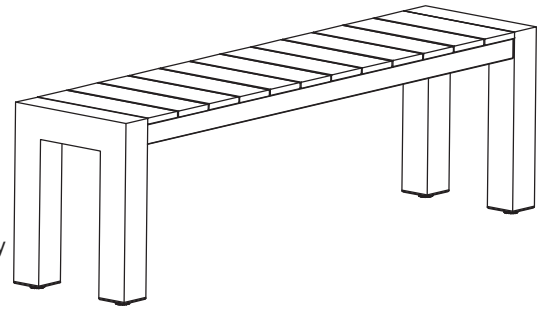

CORSICA







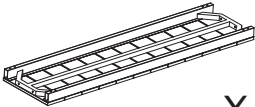
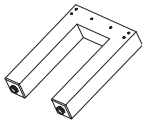

Assembly Instructions: Corsica Aluminium Bench

Before assembly please check you have all parts listed below.

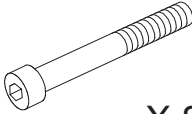
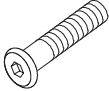
PLEASE NOTE: We've tried to make this bench as easy to assemble as possible. In the unlikely event you have problems putting it together or missing pieces, please contact us. Details below.

PARTS LIST

A bench top	B Legs	C bracket	D allen key	E (m6x90 screw)	F (m6x45 screw)
 X 1	 X 2	 X 4	 X 1	 X 8	 X 4
 X 8	 X 20	 X 20	**PROTECT YOUR BENCH DURING ASSEMBLY** To protect your bench top from scratches during assembly, please assemble on the cardboard box.		

Step 1

Screw C to legs.

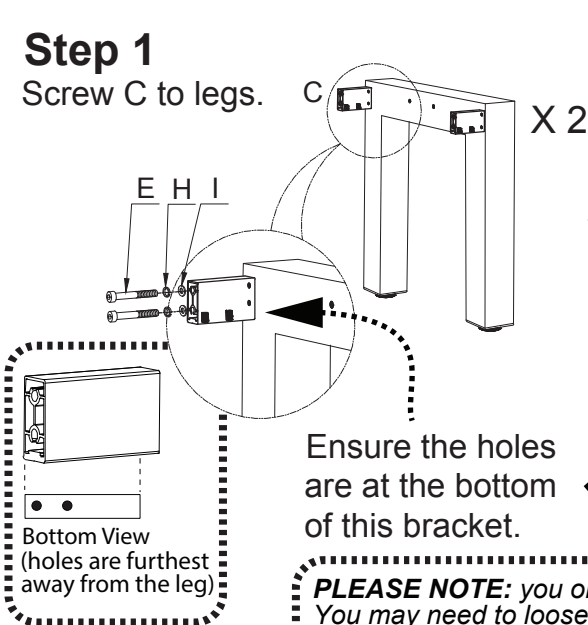

Step 2

Slide together. Ensure holes in bench top & leg bracket line up (see step 3).

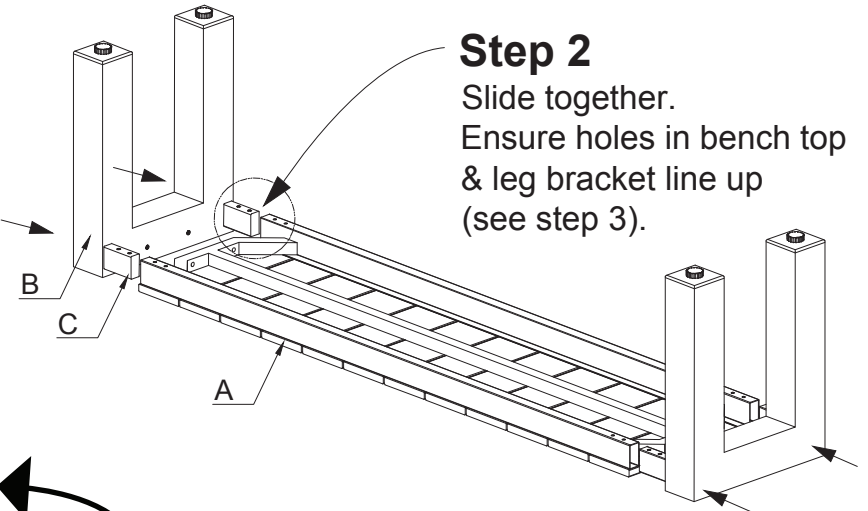

PLEASE NOTE: you only need to hand tighten this bracket (C). You may need to loosen one bracket if the bench top does not slide smoothly into place. (These do not need to be tightened further.)

Step 3

Do not over tighten screws

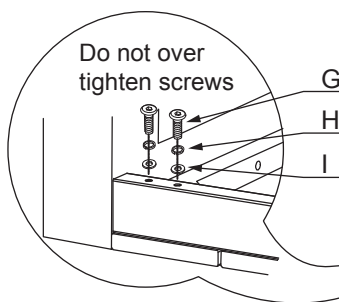

Step 4

Do not over tighten screws

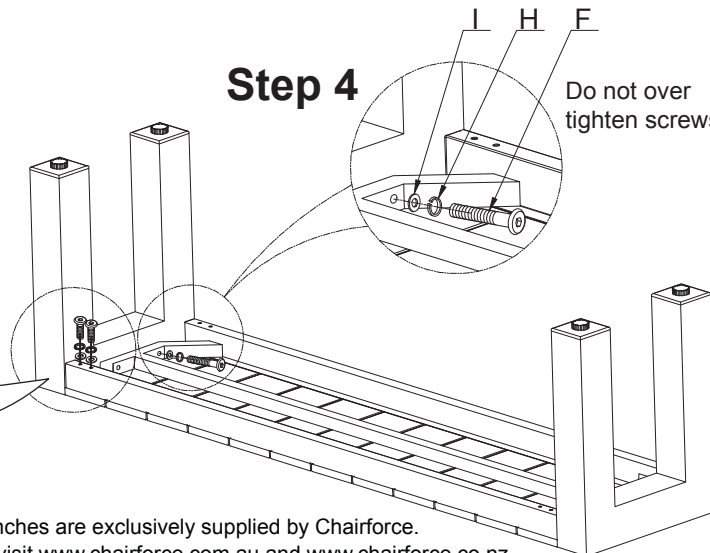

Step 5

Now tighten all screws.

Thank you for your purchase. Corsica benches are exclusively supplied by Chairforce.
 To learn more about our products please visit www.chairforce.com.au and www.chairforce.co.nz

AU: Call: 08 9436 8570 Email: customercare@brayco.com.au
 NZ: Call: 09 271 5000 Email: sales@chairforce.co.nz



Please recycle these instructions